

# Installation & Commissioning instructions

For

**OIL OR WATER PRESSURE GENERATOR**

**HPG**



## CONTENT

CONTENT .....	2
COMMISSIONING INSTRUCTIONS FOR HYDRAULIC PRESSURE COMPARATORS .....	3
Installation / Assembly .....	3
Commissioning .....	4
Instructions for use of single piston pressure generators HPG1.....	5
Instructions for use of dual piston comparators HPG2-1250, HPG2-2000, HPG2-6000 .....	6
Precautions during use .....	7
COMMISSIONING INSTRUCTIONS FOR DEAD-WEIGHT TESTERS .....	8
Installation / Assembly .....	8
Commissioning .....	9
MAINTENANCE .....	11

Model CI-X-13-090313-01  
P -Man HPG2-E-0115-1

## COMMISSIONING INSTRUCTIONS FOR HYDRAULIC PRESSURE COMPARATORS

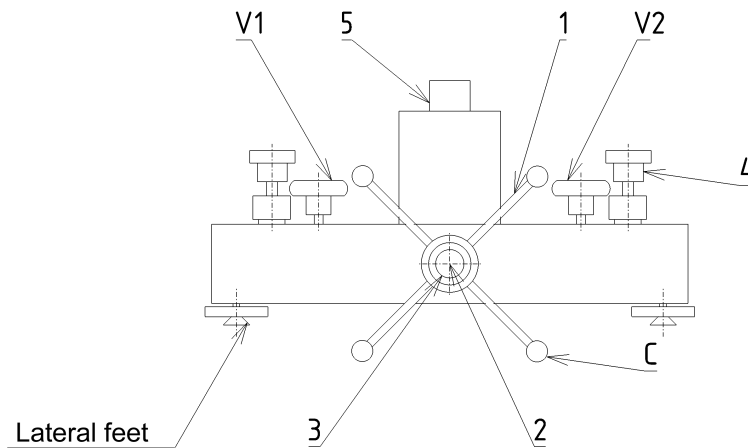

### Installation / Assembly

- Install the pressure generator on a rigid and stable stand of about 0,90 m height.
- Adjust the stability and set the level of the pressure generator with the help of the lateral feet.
- Insert the capstan C on the rotational axis 2, tighten the clamping button 3 at the end of turing shaft.
- Remove the yellow caps.
- Make sure that the joint surfaces are clean and properly positioned.
- Install the 2 adapters with swivel nuts 4 on the pressure ports.
- Make sure that the joint surfaces are clean and properly positioned.

For HPG2 – 2000 to 6000, operations a) – b) – c) – d) are identical, then :

- Fit the G1/2 connections that were supplied to the generator outlets, with the joints (aluminium, copper or dual component) – Maximum operating pressure - 1250 bars.
- Go to section 1.2 – *operating pressure in excess of 1250 bars.*

#### **IMPORTANT**

**Dirty or polluted gauges must be cleaned before being mounted on the pressure generator to prevent contamination of the hydraulic circuit.**



## Commissioning

### IMPORTANT

Since measuring benches and balances are fitted with instrumentation valves, it is essential to observe the following recommendations for preserve your equipment is good working order :

- Maximum torque applicable to the stop with open valve : 0,3 Nm
- Maximum torque applicable to the stop with closed valve : 4 Nm

When the open valve stop is reached, turn the valve wheel  $\frac{1}{4}$  turn in a clockwise direction.

a) Open the valves V1 – V2   and turn the capstan C  clockwise until the front stop is reached.

b) Open the filling cap 5 and fill the reservoir three quarters full with H15, H40, H68 oil or demineralised water for pressure generators using water. Replace the cap.

**Mount the device to be tested on one of the swivel fittings and the calibration gauge on the other fitting.**

c) Turn the capstan C  an anti-clockwise till the rear stop is reached.

d) Turn the capstan C  clockwise till the front stop is reached (purge the hydraulic circuit)

e) Turn the capstan C  an anti-clockwise till the rear stop is reached



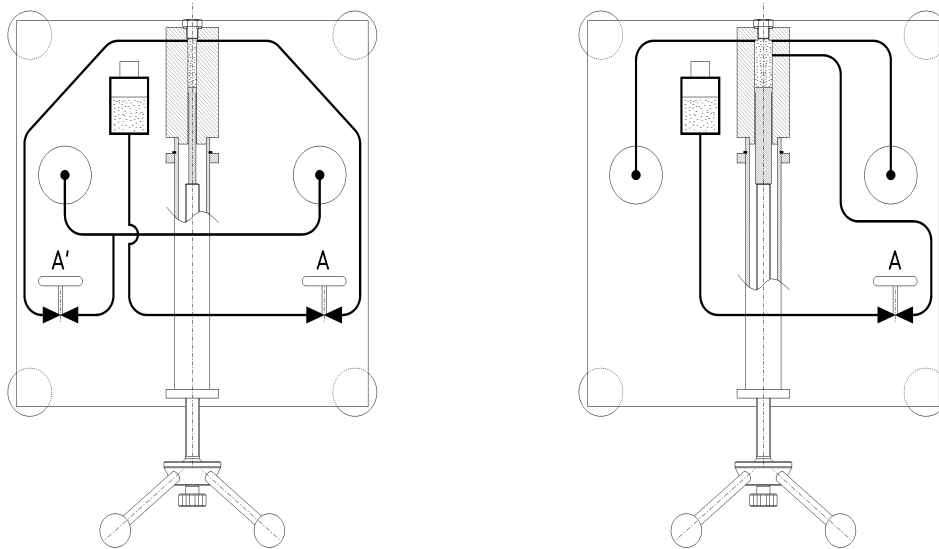

**The pressure comparator is ready for use.**

## Instructions for use of single piston pressure generators HPG1

### Hydraulic diagram





### Operation





- Open the two valves (A, A')   (valve A' is not identified on the housing).
- Verify that the pressure generator shaft is at the rear stop (capstan C) 
- For the models HPG1 close the valve A , turn the capstan C  clockwise this will increase the pressure up to 120 bar (maximum operating pressure : 150 bar).

### You should make measurements in this zone.



- Pressure generators working at high pressures (HPG1-700 and HPG1-1250) are fitted with two valves A and A'. This allows several up and down movements of the piston to fill the instruments to be checked. The valve A' must be used only for the filling, it must remain open. During measurement :

- Close the valve A 
- Turn the capstan C  clockwise

→ If the pressure is not enough

3. Close the valve A' 
4. Open the valve A 
5. Turn the capstan C  an anti-clockwise.
6. Close the valve A 
7. Open the valve A' 

→ Repeat the operation 3 if it necessary.

- e) After measurement operation, turn the capstan C  an anti-clockwise till the rear stop is reached and open the valve A slowly .
- f) The measuring instruments can be dismantled.





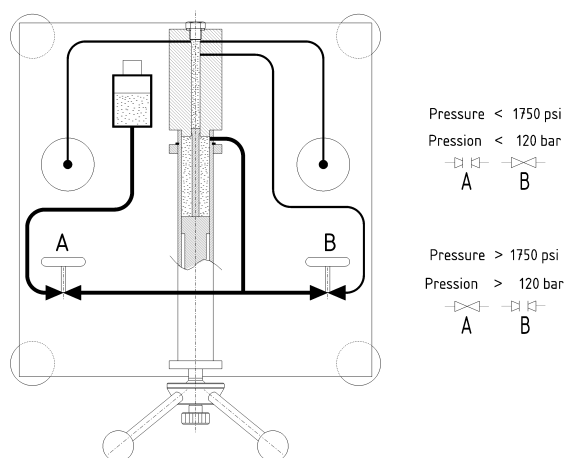



## Instructions for use of dual piston comparators HPG2

### Hydraulic diagram





Model CI-X-13-090313-01  
P - Man HPG2-E-0115-1

## Operating mode

- a) Open the two valves (A and B)  
- b) Verify that the pressure generator shaft is at the rear stop (capstan C) 
- c) Close the valve A , turn the capstan C  clockwise: this will increase the pressure up to 120 bar (maximum working pressure: 150 bar). You should make measurements in this zone.
- For generating higher pressure, close the valve B  then open the valve A ,
- turn the capstan C  clockwise. Maximum working pressure:
- 850 bar for pressure generators using water HPG2-800W
  - 1270 bar for pressure generators HPG2-1250
  - 2020 bar for pressure generators HPG2-2000
  - 4020 bar for pressure generators HPG2-4000
  - 5020 bar for pressure generators HPG2-5000

### You should make measurements in this zone.

- d) After measurement operation, turn the capstan C  an anti-clockwise till the rear stop is reached. Open the valve B .
- e) The measuring instruments can be dismantled.

## Precautions during use

- Respect the maximum pressure indicator for the use of the comparator.
- Use exclusively H40 or H15 or H68 (depending on the model). Do not dismantle the protective housing.
- Performance and functional guarantees are valid only if these oils are used.

## REMARKS

The capacity of the loading pump (60 cm<sup>3</sup>) may prove inadequate for filling a high volume measuring instrument. In such a case, a possible solution is an intermediate cock which may be positioned between the bench and the instrument. The cycle may be repeated as many times as necessary. A special accessory can be supplied for these applications.

It is also possible to pre-fill the sensing element of such a device prior to mounting it on to the pressure generator.

## COMMISSIONING INSTRUCTIONS FOR DEAD-WEIGHT TESTERS

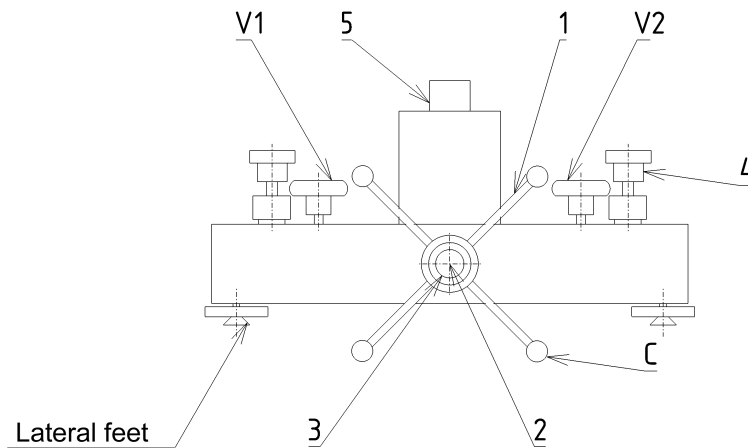

### Installation / Assembly

- Install the pressure generator on a rigid and stable stand of about 0,90 m height.
- Adjust the stability and set the level of the pressure generator with the help of the lateral feet.
- Insert the capstan C on the rotational axis 2, tighten the clamping button 3 at the end of turing shaft.
- Remove the yellow caps.
- Make sure that the joint surfaces are clean and properly positioned.
- Mount the piston-cylinder unit on the left fitting and the swivel nut adapter 4 on the right fitting. For HDWT-D-2000 to 6000 introduce the oval bushing between the piston-cylinder assembly and the base.

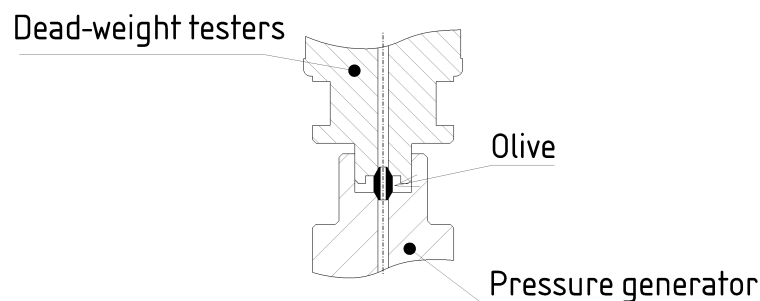

- Tighten the instrument to be calibrated with an aluminium, copper or bimetal sealing joint on the swivel nut adaptor 4.







**IMPORTANT**

**Do not use pressure gauges which are dirty or contaminated by chemical compounds without cleaning them beforehand, they can contaminate the tester and cause serious damage to the piston-cylinder unit.**

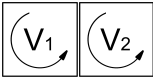
**The mounting of a chemical seal is recommended for calibrating instruments that are used for corrosive products so that traces of these products do not lead to a chemical attack on the tester circuit and in particular on the piston-cylinder unit.**

**Commissioning**

- a) Open the valve (s) V1 – V2  turn the capstan C  clockwise until the front stop is reached.
- b) Open the filling cap 5 and fill the reservoir three quarters full with H15, H40, H68. Replace the cap. Mount the device to be tested on the swivel 4.
- c) Turn the capstan C  an anti-clockwise till the rear stop is reached.
- d) Turn the capstan C  an anti-clockwise till the front stop is reached (purge the hydraulic circuit).
- e) Turn the capstan C  an anti-clockwise till the rear stop is reached.

**The dead weight tester is ready for use.**

**REMARKS:**

Reference pressure of the tester.

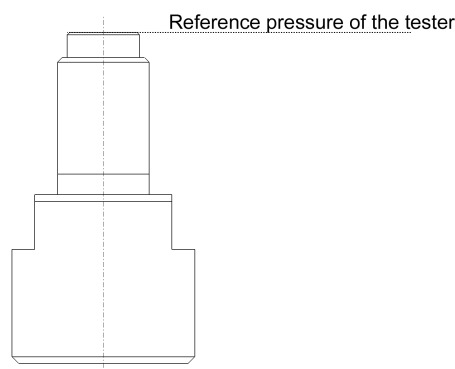



The sizes available are : G1/8, G1/4, G1/2, G3/8, 1/8BSP-TR, 1/4BSP-TR, 3/8BSP-TR, 1/2BSP-TR, 1/8NPT, 1/4NPT, 3/8NPT, 1/2NPT, M10x100, M12x150, M16x150, M18x150 and M20x150.

Model CI-X-13-090313-01  
P -Man HPG2-E-0115-1

## MAINTENANCE

### IMPORTANT :

- The piston-cylinder unit is designed for extremely narrow pressure limits. Therefore dismantling is forbidden.
- Since measuring benches and balances are fitted with instrumentation valves, it is essential to observe the following recommendations :
  - maximum torque applicable to the stop with open valve = 0.3 Nm
  - maximum torque applicable to the stop with closed valve = 4 NmWhen the open valve stop is reached, turn the valve wheel  $\frac{1}{4}$  turn in a clockwise direction.
- Do not use liquids other than H40 oil. Fluids such as Skydrol and solvents may damage joints mounted on a tester or on a standard pressure generator.
- In particular, keep oil in the reservoir under control for detecting traces of pollution by external sources.

### KEEP THE TESTERS AND THE WEIGHTS CLEAN :

- Wipe clean the O-rings under: the piston-cylinder unit, swivel nut adapter.
- A slight leak through the piston-cylinder unit is normal.
- If the oil from the tester is dirty, purge the hydraulic circuit by means of the pressure generator and a tube screwed on the swivel nut adapter (the elbow connector G1/2A suits perfectly).
- Do not use cleaning solutions as these can damage the O-rings.
- The piston-cylinder unit represents an important part in the value of the tester. It should be handled with care and kept clean. If for some reason, the piston-cylinder unit is removed, place it vertically on a clean surface.
- In case of damage of the piezometric unit, send back the complete unit for replacement or repair.
- The serial number of the piston-cylinder unit appears on the accuracy certificate and on the body of the unit. Quote this number and also the serial number of the tester during all correspondence related to the piston-cylinder unit.

If required, the dead-weight tester may be sent back to our facility.